

Lantek flex3d steelwork

The key to your business

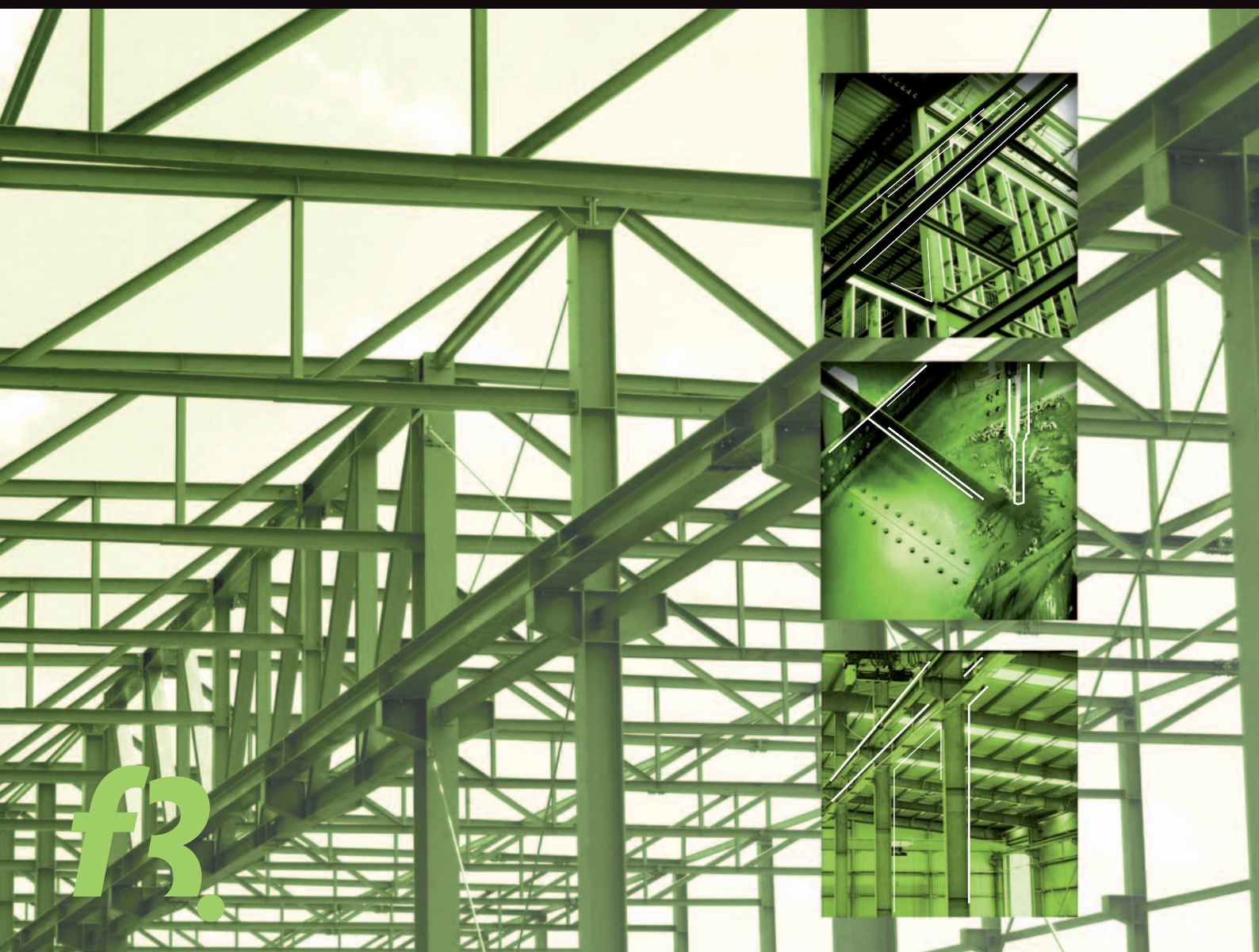

f3



Introduction

The structural steel sector is responsible for designing the large structures of our world. Our lives depend on the efficacy of the structures produced by this industry, which adheres to stringent regulations. **Lantek Flex3d Steelwork** is sophisticated software designed to control the production and manufacturing of steel products and prefabricated structures.

Easy and flexible design

Lantek Flex3d Steelwork includes 2D and 3D design, CNC programming of profiles, integration with third party structural design software, and ERP capabilities to control costs and optimize return on investment. This module, when integrated with the **Lantek Flex3d Steelwork** System, facilitates the 3D CAD/CAM design and cutting of standard profiles including: I, U, L, H, T, and square or round tubes. The automatic and semi-automatic features of the 3D nesting software maximize the use of materials and optimize the CNC code with collision avoidance technology as well as safe and efficient cutting operations on a wide range of machinery such as: sawing, drilling, punching, tapping, marking, oxycut, and plasma equipment.

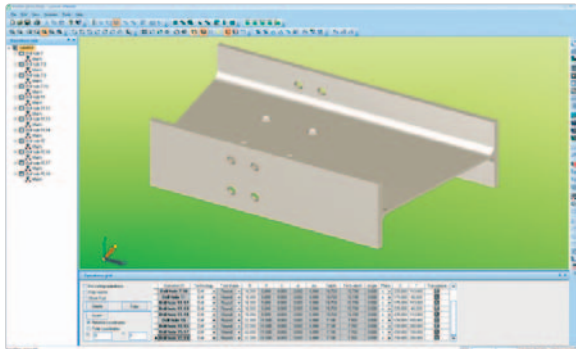

Once the design process is completed, the user can simulate the head movement of the machine, the beam or tube movement, and the machining operations of

every tool in 3D. The user can also generate the NC file and send it directly to the machine. **Lantek Flex3d Steelwork** can be adapted to work with any beam or tube machine.

When **Lantek Flex3d Steelwork** is linked with **Lantek Expert**, it can design nest and CNC program 2D sheet metal profiles. This software includes a wide range of functionality such as automatic and manual nesting, lead-in contour management, common line cutting, tool path transformation, CAD interfaces and layer management. When linked with **Lantek Integra** ERP technology, Steelwork enables management to have process and cost controls from any location with Internet service.

This is a module of ultimate flexibility that brings together design, manufacturing and production management. The harmonic created with this software permits companies to operate more efficiently, to deliver projects on time, to control costs, and to achieve profitability goals.

Technical characteristics

Lantek Flex3d Steelwork is a system that includes database technology. This eliminates the need for the user to continuously duplicate the entry of information to create a beam or tube section. The parametric technology of this system allows the user to select a base section and then modify the measurement. The result is complete management of different profile products and remnants that are rapidly available on file.

While **Lantek Flex3d Steelwork** may be a standalone product, it is maximized when integrated with the **Lantek Manager** and **Lantek Integra** Management Software Systems (MES/ERP). This integration incorporates features that start at the sales quotation level (jobs or projects) and continue with the launch of orders and production flow including: material needs, reservation management, purchases, and cost controls. It also incorporates workshop data collection, the integral management of warehouses, inventory of beams, sheet metal, tubes, remnants, commercial products, and finished goods. The system has total traceability management.



• DSTV, SAT and CAM Importers

Lantek Flex3d Steelwork imports data generated by the leading structural steel CAD systems using DSTV, SAT and CAM files. The system converts the DSTV, SAT and CAM files into the native format for **Lantek Flex3d**, which easily allows the user to apply modifications. In addition, this module will import various properties of a file, such as the material, quantity and thickness -- all of which simplify the process for cutting preparation.

• Design options

Lantek Flex3d Steelwork not only performs basic operations such as drilling, shearing, marking and sawing, it also creates cutting operations from geometry imported from the **Lantek 2D** module and imports file formats such as DXF.

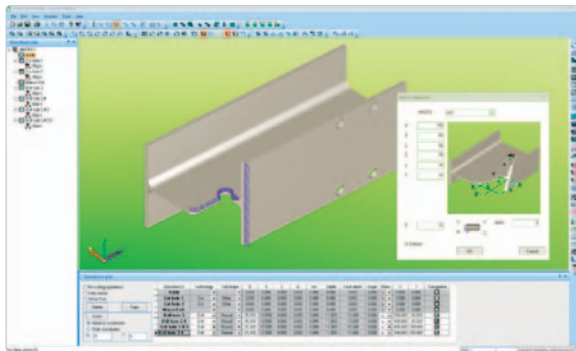

Lantek Flex3d Steelwork performs the following operations:

- Automatic and Semi-automatic drilling, tapping, and sinking operations along the profile (any flanges and/or web)
- Automatic and Semi-automatic cutting operations (plasma, oxycut, sawing or shearing)
- Automatic tools for text and contour making operations (scribing, contour marking, plasma)

- Cutting macros, which include parametric operations and drive any 5 or 6 axis cutting head (bevel cutting)
- Stored machining along the beam or tube section, which keeps the related profile for easy modification

• Optimization and profile cutting

Lantek Flex3d Steelwork allows the user to obtain the optimized profile path and to generate the CNC file for the machine.

The system is optimized further by importing sections from the warehouse automatically or by calculating the supply needs.

Automatic, Semi-automatic or Manual 3D Nesting

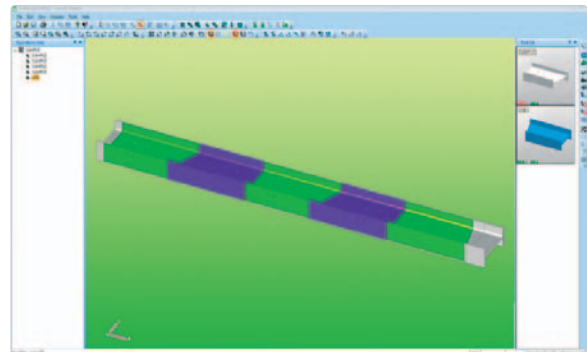

Automatic or Manual Lean-in Lead-out Generation

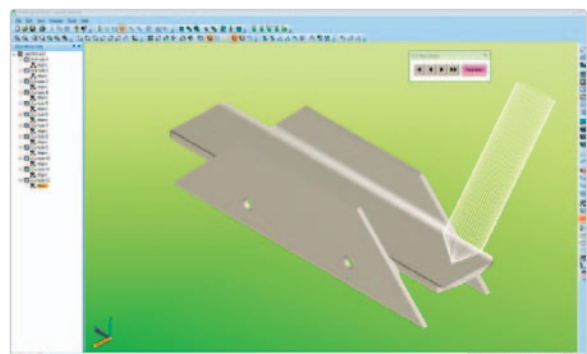

lantek
Lantek Sheet Metal Solutions S.L.

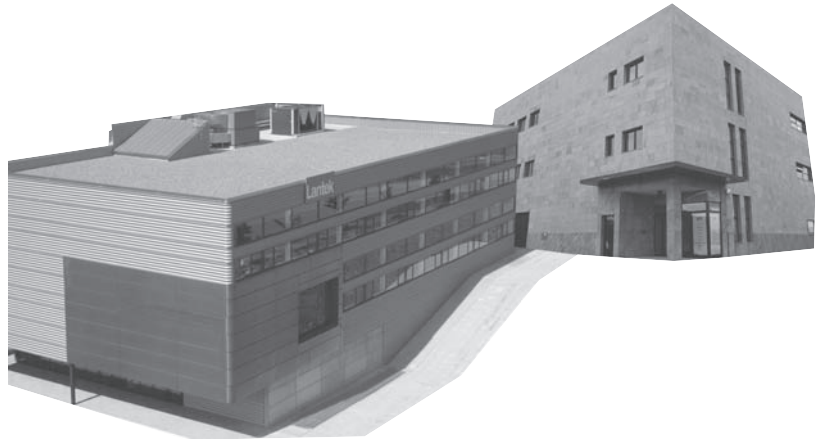

ARGENTINA BRAZIL CHINA CZECH REP. FRANCE
GERMANY INDIA ITALY JAPAN MEXICO POLAND
RUSSIA SOUTH KOREA SPAIN TURKEY U.K. U.S.A.

www.lanteksms.com
marketing@lantek.es

Lantek Flex3d Steelwork offers tools that automatically detect and control collisions as well as make manual modifications.

Also, there are several relevant reports and process forms generated for the convenience of the user.

The user can see all of the parameters of cutting during the simulation and, while viewing, make zoom movements, rotations or axis positioning adjustments to the profile. Viewing is totally interactive during simulation with options for viewing step-by-step, forward or rewind.

• Cutting profiles simulation

Lantek Flex3d Steelwork allows the user to simulate each machining operation whether it is drilling, punching, the cutting head, or the work zone. If the resultant simulation is acceptable to the user, **Lantek Flex3d Steelwork** will automatically generate the NC file for the machine and the user can view this data in the same environment. As seen in the illustrations, the simulation is of all machining operations and the trajectory of the cutting head (plasma or oxycut). When collisions are found, the user can repair them by stopping the simulation and correcting the trajectory.

